

- Remove the ball and pass the fan switch chain through the hole in top of fitter.
- Proceed to "Installation of Glass Bowl" section.

Installation of Glass Bowl

WARNING

To avoid fire hazard, do not exceed two 60-watt (maximum) candelabra base light bulbs.

- Install a 60-watt (maximum) candelabra base light bulb (not included) into each of the two lamp holder sockets.
- Thread fan switch chain through hole in glass bowl, then position the glass bowl (1), felt washer and bowl decoration (2) onto the fitter threaded nipple. Install a hex nut (provided) onto the threaded nipple and tighten to secure the glass bowl and the bowl decoration in place. Install finial (3) finger tight.

- Install balls onto light fixture chain and fan switch chain.

NOTE: It is advisable to periodically check the tightness of the finial.

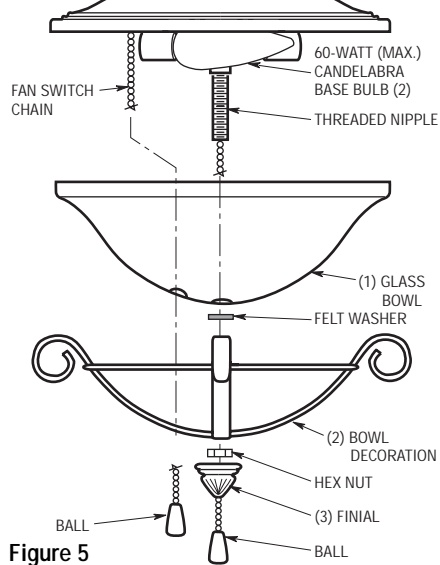

Figure 5

LIMITED WARRANTY

What The Warranty Covers:

All products covered by this Owner's Manual are warranted against all defects in workmanship and materials. You must be the original purchaser or user of the product to be covered.

What The Period Of Coverage Is:

All components are covered by this warranty for one year from the date you purchased your light fixture. ANY IMPLIED WARRANTY OF MERCHANTABILITY OR FITNESS FOR A PARTICULAR PURPOSE, MADE WITH RESPECT TO COMPONENTS AND ACCESSORIES IS ALSO LIMITED TO ONE YEAR.

What Will Emerson Electric Co. Do To Correct Problems:

Emerson Electric Co. will replace a defective Emerson Light Fixture at no charge to you. WE WILL SHIP THE REPAIRED PRODUCT OR REPLACEMENT TO YOU AT NO CHARGE, BUT YOU ARE RESPONSIBLE FOR ALL COSTS OF REMOVAL, REINSTALLATION AND SHIPPING OF THE PRODUCT TO EMERSON ELECTRIC CO.

How Can You Get Service:

YOU MUST HAVE PROOF OF YOUR PURCHASE OF THE LIGHT FIXTURE TO OBTAIN LIMITED WARRANTY SERVICE. KEEP YOUR RECEIPT OR OTHER PROOF OF PURCHASE. You can return the product to our factory or to your nearest authorized service center.

- To return the product to the factory, obtain a return authorization and service identification tag by writing to Air Comfort Products, Division of Emerson Electric Co., 8100 W. Florissant Ave., St. Louis, MO 63136. Include all model numbers shown on the product with your request.
- To return the product to an authorized service center, call 1-800-654-3545 for the address of the nearest authorized service center.

You will be responsible for all insurance, freight or other transportation charges to our factory or authorized service center. Your Emerson Light Fixture should be properly packed to avoid damage in transit since we will not be responsible for any such damage.

What Is Not Covered:

This warranty also does not cover any defects, malfunctions or failures caused by:

- Repairs by persons not authorized by Emerson Electric Co.,
- Use of parts or accessories not authorized by Emerson Electric Co.,
- Mishandling, improper installation, modifications or damage to your light fixture while in your possession, or
- Unreasonable use, misuse, abuse, including failing to do reasonable and necessary maintenance, and normal wear and tear.

Additionally, this warranty and any implied warranty of merchantability or fitness for a particular purpose are voided when:

- The original purchaser or user ceases to own the product, or
- The ceiling fan is moved from its original point of installation.

This warranty is only valid within the 50 states of the United States and the District of Columbia. No other written or oral warranties apply, and no employee, agent, dealer or other person is authorized to give any warranties on behalf of Emerson Electric Co.

REPAIR, REPLACEMENT OR A REFUND ARE THE EXCLUSIVE REMEDIES AVAILABLE UNDER THIS WARRANTY AND EMERSON IS NOT RESPONSIBLE FOR DAMAGES OF ANY KIND, INCLUDING INCIDENTAL AND CONSEQUENTIAL DAMAGES. Incidental damages include but are not limited to such damages as loss of time and loss of use. Consequential damages include but are not limited to the cost of repairing or replacing other property which was damaged if this product does not work properly.

How State Law Relates To The Warranty:

Some states do not allow the exclusion or limitation of incidental or consequential damages so the above exclusion or limitation may not apply to you. This warranty gives you specific legal rights, and you may also have other rights which vary from state to state.

READ AND SAVE THESE INSTRUCTIONS

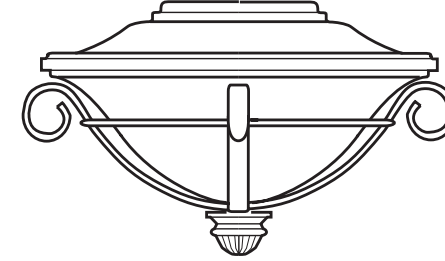

Wrought Iron Bowl

Model No.

LK12
Series

SUITABLE FOR DAMP LOCATIONS
TWO 60-WATT CANDELABRA BASE BULBS

Net Weight: 4.9 Lbs.



EMERSON™

Ceiling Fan Light Fixture Owner's Manual



EMERSON

Air Comfort Products

DIVISION OF EMERSON ELECTRIC CO.
8100 W. Florissant • St. Louis, MO 63136

Part No. BP7184-3
Form No. F40BP71840003

Printed in China 09/06

Form No. F40BP71840003

Part No. BP7184-3
U.L. Model No.: LK12

Safety Instructions

WARNING: To avoid fire, shock, and serious personal injury, follow all instructions carefully.

1. Read your Owner's Manual carefully before installing the light fixture. Retain Owner's Manual for future reference.
2. Be careful of the fan and blades when cleaning, painting, or working near the fan. Before installing or servicing the light fixture or ceiling fan, switch power off at service panel and lock service panel disconnecting means to prevent power from being switched on accidentally. When the service disconnecting means cannot be locked, securely fasten a warning device, such as a tag, to the service panel.
3. Do not exceed the wattage indicated on fixture (two 60-watt candelabra base bulbs, maximum).

ADDITIONAL SAFETY INSTRUCTIONS FOR INSTALLATION

1. To avoid possible electrical shock be sure electricity is turned off at the main fuse or circuit breaker box before wiring.
2. Make certain no bare wires are exposed outside the wire connectors.
3. All wiring must conform to national and local electrical codes.
4. Follow the recommended instructions for the proper method of wiring your new light fixture. If you feel you do not have enough electrical wiring knowledge or experience, have your light fixture installed by a licensed electrician. Any electrical work not described in this manual should be performed by a licensed electrician.

WARNING: To reduce the risk of possible fire and electrical shock, install only on Emerson CF and F Series Ceiling Fans. Permissible to use this light fixture with CF652, CF653, CF670, CF680, CF742, and CF2000 Series Ceiling Fans installed in damp locations.

Assembly and Installation

WARNING

Do not install or use the light fixture if any part is missing or damaged. Contact your dealer for replacement.

WARNING

To avoid possible electrical shock, be sure electricity is turned off at the main fuse or circuit breaker box before wiring.

Installation on Emerson Fans Having a Modular Switch Cup with Center Screw

1. Remove all parts and parts packages from the carton.
2. Remove the switch cup (1) from the cover plate (2) by removing the three screws (3) around the side of the switch cup (Figure 1).
3. Disconnect the motor connector (4) from the switch cup connector (5) (Figure 1).

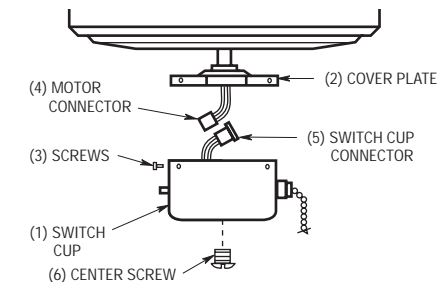

Figure 1

4. Remove the center screw (6) from the switch cup (Figure 1).
5. Carefully locate the white and blue wires (labeled either "L" or "LIGHT") in the switch cup and remove the wire connectors from the wires.
6. Insert the black and white wires from the light fitter (7) through the center hole in the switch cup (Figure 2) and thread the switch cup onto the light fitter. Hold wires taut while installing switch cup to prevent the wires from twisting. Tighten the fitter until the fan switch chain aligns with the hole in the fitter.

7. Insert the black and white wires through the lockwasher and hex nut (supplied), firmly tighten the hex nut to secure the light kit fitter to the switch cup. Connect the white wire from the switch cup to the white wire of the light fitter (Figure 2). Connect the blue wire from the switch cup to the black wire of the light fitter. Use listed wire connectors (previously removed in step 5) to make connections (Figures 2 and 3).

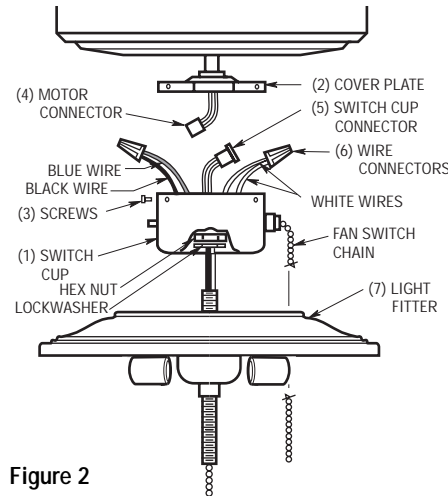

Figure 2



WARNING: To avoid possible fire or electrical shock, make certain no bare wire strands are exposed outside wire connectors.

Figure 3

8. Carefully tuck all wires and splices into the switch cup (1). (Figure 2.)
9. Connect the motor connector (4) to the switch cup connector (5).
10. Position the cup/light fitter (1)(7) on the cover plate (2) and install the three screws (3) that were previously removed in step 2 and tighten securely.

WARNING

To avoid possible fire or electric shock, be careful not to pinch wires between switch cup and the cover plate.

11. Remove the ball and pass the fan switch chain through the hole in top of fitter.
12. Proceed to "Installation of Glass Bowl" section.

Installation on Emerson Fans Having Two-Piece Die-Cast Switch Housings

1. Remove all parts and parts packages from carton.
2. Remove the cover from switch housing (1) below ceiling fan. Replace screws (2) loosely in switch housing. Do not tighten. (Figure 4.)
3. Carefully pull down white and blue wires from the switch housing and remove wire connectors.
4. Connect the white wire from the ceiling fan to the white wire of the light fitter (4). Connect the blue wire from the ceiling fan to the black wire of the light fitter. Use listed wire connectors (previously removed in step 3) to make connections. (Figures 3 and 4.)
5. Carefully tuck all wires and splices into the switch housing (1).
6. Position the light fitter (7) so that the hole in the fitter aligns with the fan switch chain. Then attach the light fitter by aligning screws (2) in switch housing (1) with keyhole slots in top of fitter. Turn light fitter slightly to hold in place and then tighten screws securely from bottom. (Figure 4.)

WARNING

To avoid possible fire or electrical shock, be careful not to pinch wires between the switch housing and the light fitter.

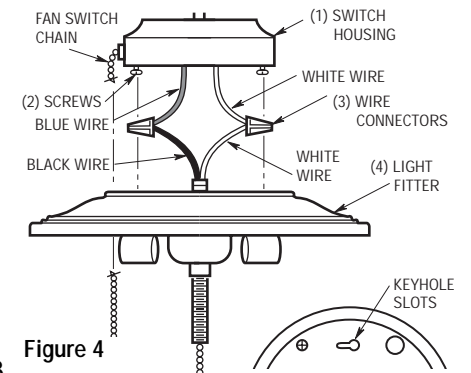

Figure 4