

LIMITED WARRANTY

What The Warranty Covers:

All products covered by this Owner's Manual are warranted against all defects in workmanship and materials. You must be the original purchaser or user of the product to be covered.

What The Period Of Coverage Is:

The fluorescent bulb and electronic ballast are covered by this warranty for two years after the date of purchase; all other components are covered for one year after the date of purchase. ANY IMPLIED WARRANTY OF MERCHANTABILITY OR FITNESS FOR A PARTICULAR PURPOSE, MADE WITH RESPECT TO COMPONENTS AND ACCESSORIES IS ALSO LIMITED TO ONE YEAR.

What Will Emerson Electric Co. Do To Correct Problems:

Emerson Electric Co. will replace a defective Emerson Light Fixture at no charge to you. **WE WILL SHIP THE REPAIRED PRODUCT OR REPLACEMENT TO YOU AT NO CHARGE, BUT YOU ARE RESPONSIBLE FOR ALL COSTS OF REMOVAL, REINSTALLATION AND SHIPPING OF THE PRODUCT TO EMERSON.**

How Can You Get Service:

YOU MUST HAVE PROOF OF YOUR PURCHASE OF THE LIGHT FIXTURE TO OBTAIN LIMITED WARRANTY SERVICE. KEEP YOUR RECEIPT OR OTHER PROOF OF PURCHASE. You can return the product to our factory or to your nearest authorized service center.

- To return the product to the factory, obtain a return authorization and service identification tag by writing to Air Comfort Products, Division of Emerson Electric Co., 8100 W. Florissant Ave., St. Louis, MO 63136. Include all model numbers shown on the product with your request.
- To return the product to an authorized service center, call 1-800-654-3545 for the address of the nearest authorized service center.

You will be responsible for all insurance, freight or other transportation charges to our factory or authorized service center. Your Emerson Light Fixture should be properly packed to avoid damage in transit since we will not be responsible for any such damage.

What Is Not Covered:

This warranty also does not cover any defects, malfunctions or failures caused by:

- Repairs by persons not authorized by Emerson Electric Co.,
- Use of parts or accessories not authorized by Emerson Electric Co.,
- Mishandling, improper installation, modifications or damage to your light fixture while in your possession, or
- Unreasonable use, misuse, abuse, including failing to do reasonable and necessary maintenance, and normal wear and tear.

Additionally, this warranty and any implied warranty of merchantability or fitness for a particular purpose are voided when:

- The original purchaser or user ceases to own the product, or
- The ceiling fan is moved from its original point of installation.

This warranty is only valid within the 50 states of the United States and the District of Columbia. No other written or oral warranties apply, and no employee, agent, dealer or other person is authorized to give any warranties on behalf of Emerson Electric Co.

REPAIR, REPLACEMENT OR A REFUND ARE THE EXCLUSIVE REMEDIES AVAILABLE UNDER THIS WARRANTY AND EMERSON IS NOT RESPONSIBLE FOR DAMAGES OF ANY KIND, INCLUDING INCIDENTAL AND CONSEQUENTIAL DAMAGES. Incidental damages include but are not limited to such damages as loss of time and loss of use. Consequential damages include but are not limited to the cost of repairing or replacing other property which was damaged if this product does not work properly.

How State Law Relates To The Warranty:

Some states do not allow the exclusion or limitation of incidental or consequential damages so the above exclusion or limitation may not apply to you. This warranty gives you specific legal rights, and you may also have other rights which vary from state to state.

For repair parts, phone:

1-800-654-3545



EMERSON

Air Comfort Products

Form No. BP7319-1
Part No. F40BP73190001

DIVISION OF EMERSON ELECTRIC CO.
8100 W. Florissant • St. Louis, MO 63136

Printed in China
01/08

READ AND SAVE THESE INSTRUCTIONS



EMERSON

Fluorescent Light Fixture

Model Numbers

LK51F

Teastained
Bowl

LK52F

Alabaster
Bowl

LK58F

Opal Matte Bowl

LK62F

Linen Bowl

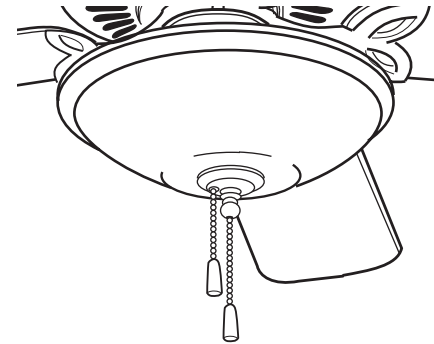

**USE THIS FIXTURE ONLY WITH
EMERSON "CF" SERIES
CEILING FANS**

**ONE 30-WATT CIRCLINE
FLUORESCENT BULB INCLUDED**

Net Weight: 4.0 Lbs.



Part No. F40BP73190001

Form No. BP7319-1
U.L. Model No.: LK51F, LK52F, LK58F, LK62F

NOTE: This equipment has been tested and found to comply with part 18 of the FCC Rules. This equipment generates, uses and can radiate radio frequency energy and if not installed and used in accordance with the instructions, may cause harmful interference to radio communications. However, there is no guarantee that interference will not occur in a particular installation. If this equipment does cause harmful interference to radio or television reception, which can be determined by turning the equipment OFF and ON, the user is encouraged to correct the interference by one or more of the following measures:

- Reorient or relocate the receiving antenna.
- Increase the separation between the equipment and receiver.
- Connect the equipment into an outlet on a circuit different from that to which the receiver is connected.

Changes or modifications not expressly approved by the party responsible for compliance could void the user's authority to operate the equipment.

Replacement of the Fluorescent Bulb

1. Remove the two pendants from the switch chains (Figure 7).

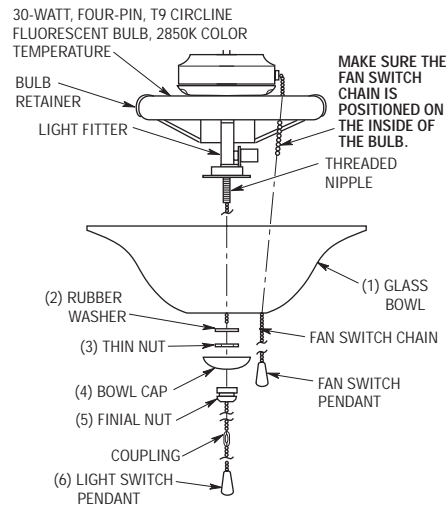

Figure 7

2. Remove the finial nut(5) and the bowl cap(4). Grasp the glass bowl(1); unscrew the thin nut(3) and remove the rubber washer(2) and the glass bowl.
3. Grasp the plastic collar on the the fluorescent bulb (Figure 5) and gently separate the light fitter connector from the bulb pins.
4. Unsnap both side of the bulb retainer and remove the defective bulb.

NOTE: Use only a 30-watt, four-pin, T9 circline fluorescent bulb, 2850K color temperature.

5. Install the replacement bulb in accordance with the "Installation of Fluorescent Bulb and Glass Bowl" section.

Replacement of the Electronic Ballast

Contact a qualified electrician for replacement of the electronic ballast.

Installation on Emerson Fans with Modular (Detachable) Switch Cups

1. Remove all parts and parts packages from the carton.
2. On the ceiling fan, remove the switch cup(1) from the cover plate(2) by removing the three screws(3) around the side of the switch cup (Figure 1).
3. Disconnect the motor connector(4) from the switch cup connector(5) (Figure 1).
4. Remove the center screw(6) from the switch cup (Figure 1).
5. Carefully locate the white and blue wires (labeled either "L" or "LIGHT") in the switch cup and remove the wire connectors from the wires.
6. Insert the black and white wires from the light fitter(7) through the center hole in the switch cup (Figure 2) and thread the switch cup tightly onto the light fitter. Hold wires taut while installing switch cup to prevent the wires from twisting.

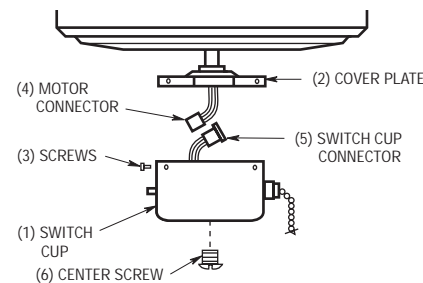

Figure 1

7. Insert the black and white wires through the lockwasher(8) and hex nut(9) supplied. Firmly tighten the hex nut to secure the light kit fitter to the switch cup.
8. Connect the white wire from the switch cup to the white wire of the light fitter (Figure 2). Connect the blue wire from the switch cup to the black wire of the light fitter. Use listed wire connectors (previously removed in step 5) to make connections (Figures 2 and 3).

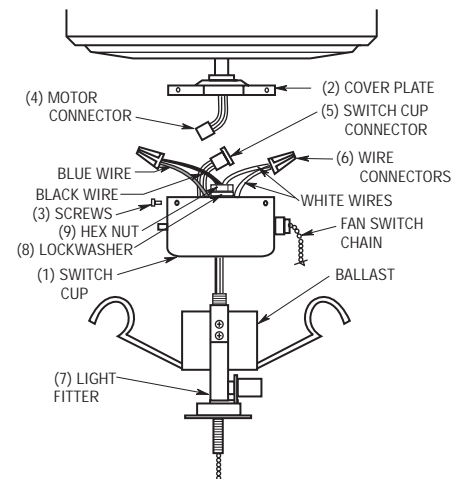

Figure 2

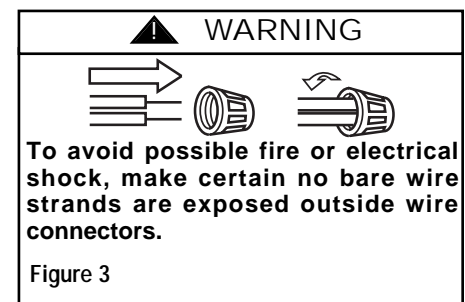

Figure 3

9. Carefully tuck all wires and splices into the switch cup(1). (Figure 2.)
10. Connect the motor connector(4) to the switch cup connector(5).

- Position the cup/light fitter(1)(7) on the cover plate(2) and install the three screws(3) that were previously removed in step 2 and tighten securely.

WARNING

To avoid possible fire or electric shock, be careful not to pinch wires between switch cup and the cover plate.

- Position the bulb retainer between the fitter bracket and the bottom of the ballast (Figure 2). Carefully snap the retainer into the groove in the ballast. Make sure the retainer is securely installed in the groove.
- Proceed to "Installation of Fluorescent Bulb and Glass Bowl" section.

Installation on Emerson Fans Having Two-Piece Die-Cast Switch Housings

- Remove all parts and parts packages from carton.

WARNING

To avoid possible electric shock, be sure electricity is turned off at the main fuse or circuit breaker box before wiring.

- Remove the cover(5) from the fan switch housing(1) by removing the two outer screws(2). (See Figure 4).
- Remove the center screw(4) from the cover(5). Insert the black and white wires from the light fitter(6) thru the hole and thread the switch housing cover tightly onto the light fitter.

WARNING

To avoid fire or electrical shock, be careful not to pinch wires between the switch housing assembly and the cover.

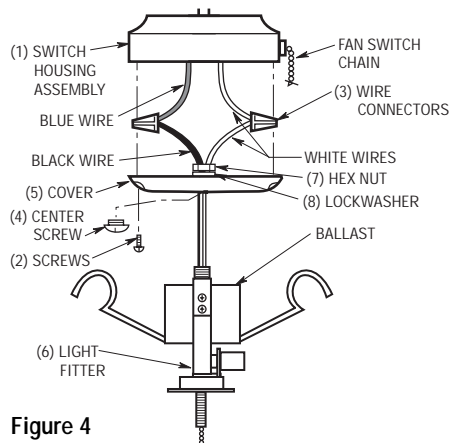

Figure 4

- Insert the black and white wires through the lockwasher(8) and hex nut(7) supplied. Firmly tighten the hex nut to secure the light fitter to the switch housing cover(5).
- Carefully locate the white and blue wires (labeled either "L" or "LIGHT") in the switch housing and remove the wire connectors(3) from the wires.
- Connect the white wire from the ceiling fan to the white wire of the light fitter(6). Connect the blue wire from the ceiling fan to the black wire of the light fitter. Use listed wire connectors(3) (previously removed in Step 5) to make connections. (Figures 3 and 4).
- Carefully tuck all wires and splices into the switch housing(1).
- Attach the cover/light fitter(5)(6) to the switch assembly housing(1) using the two screws(2) that were removed in Step 2) (Figure 4.)

- Position the bulb retainer between the fitter bracket and the bottom of the ballast (Figure 4). Carefully snap the retainer into the groove in the ballast. Make sure the retainer is securely installed in the groove.
- Proceed to "Installation of Fluorescent Bulb and Glass Bowl" section.

Installation of Fluorescent Bulb and Glass Bowl

WARNING

To avoid fire hazard, do not exceed wattage indicated on the fixture.

- Carefully position the T9 Circline 30-watt bulb (supplied) under the bulb retainer, making sure that the bulb pins are located at the bottom, near the light fitter connector (Figure 5). Carefully snap both sides of the bulb retainer over the bulb.
- Support the fluorescent bulb at the plastic collar and carefully engage the light fitter connector with the bulb pins.
- Make sure the fan switch chain is positioned through the inside of the fluorescent bulb (Figure 6). Then remove the pendant and thread the switch chain through the hole in the glass bowl(1). Position the glass bowl over the threaded nipple and then secure by installing the rubber washer(2) and thin nut(3) finger tight. (Rubber washer and thin nut are supplied in parts bag.) Install the bowl cap(4) and finial nut(5) finger tight.

NOTE: Be sure the switch chain hole in the glass bowl(1) is positioned directly under the fan switch as shown in Figure 6.

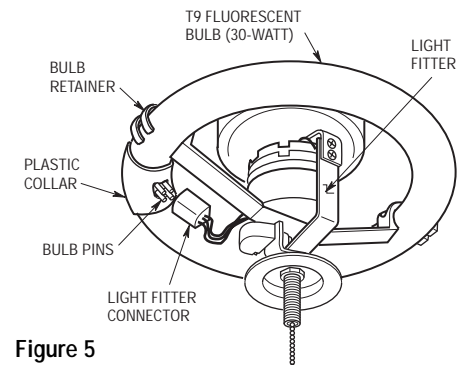

Figure 5

- Install the fan switch pendant on the fan switch chain (Figure 6). Engage the coupling on the light pendant/chain with the light switch chain.

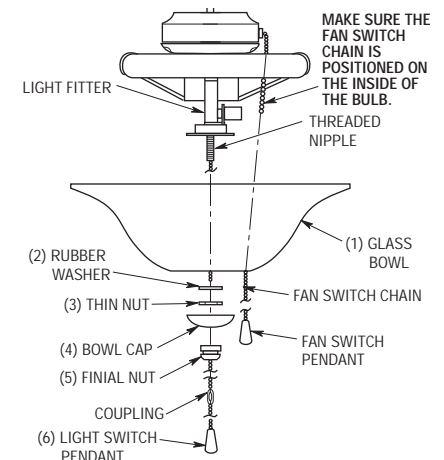

Figure 6

- Installation is now complete. Turn on the electricity at the main fuse or circuit breaker box.